

**BASIC MODIFICATION OF THE BC-457, BC-458 or BC-459
AS A VFO FOR MODEL 10 or 20 MULTIPHASE EXCITER FOR 12 VOLT OPERATION**

The contacts on the keying relay (beneath the chassis) should be closed by using jumpers or soldering the contacts together. This applies B plus to the oscillator and also grounds the cathode circuit on the 1625 stage. Remove the 1629 eye tube and also the 1625 located near the tuning shaft. Jumpers should be installed across the filament terminals of these unused sockets. Only one 1625 is necessary for proper operation.

The antenna loading coil and antenna relay are not necessary and can be removed. The co-ax cable to the Exciter can be attached directly to the output link of the 1625 final tank coil.

Plate voltage for the VFO is supplied from the Exciter through an octal socket on the rear.

The electrical connections for the external wiring are shown below.

Advance the antenna coupling adjustment on the VFO to the point where additional coupling will not increase the Exciter output. Over-injection to the mixer will generate harmonics of the VFO frequency that can appear in the output as spurious radiation.

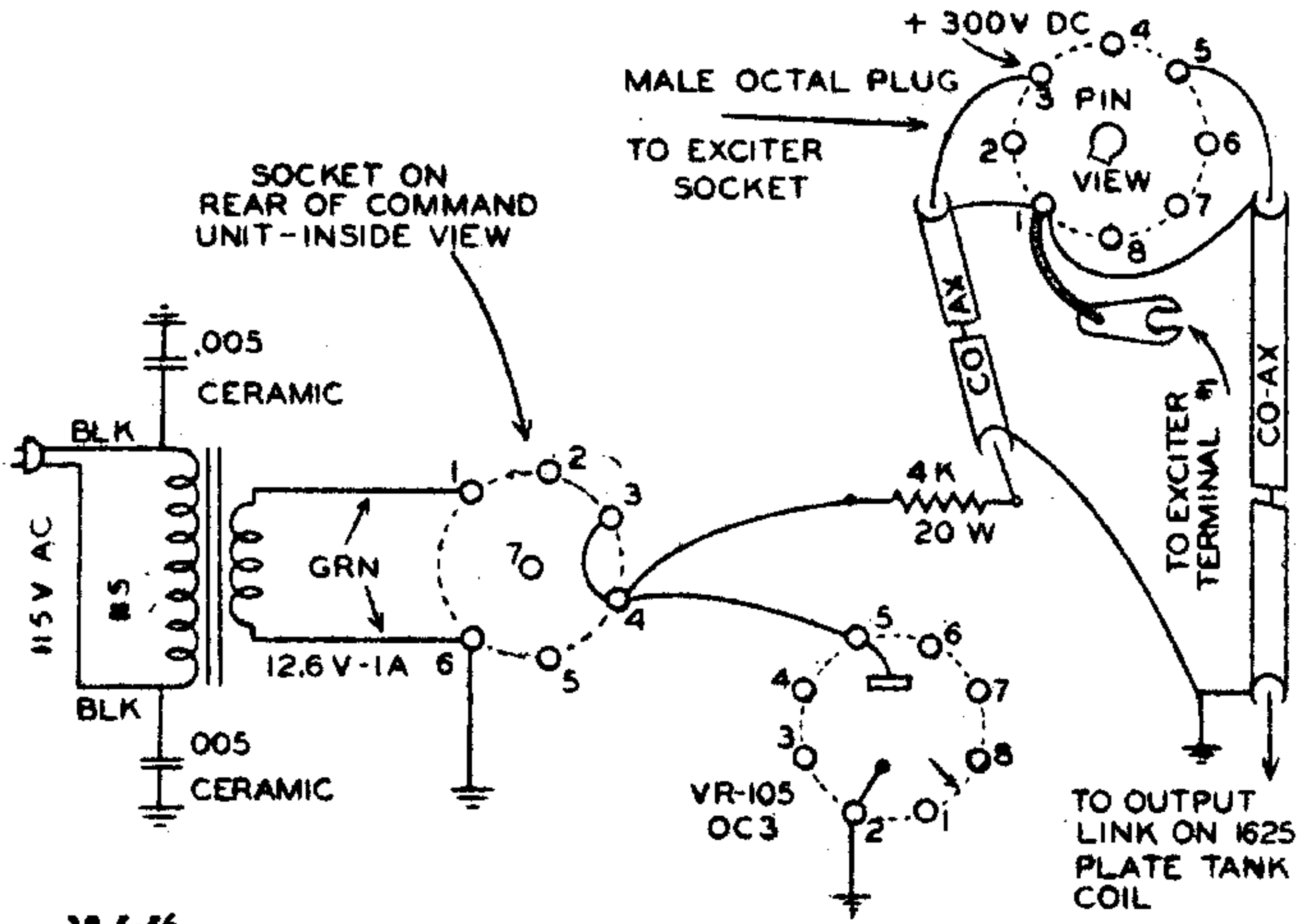

10-5-56
VFO for 10 - 20

MV131
108-9 MX

BC 458 VFO CHANGE NOTICE

There have been several cases where oscillation or regeneration has been experienced with the 10A, 10B and 20A Exciters on the higher frequency bands. It has been determined that the coaxial cables to the 458 VFO can pick up radiated RF due to inadequate shielding. The use of Amphenol #21204 Triaxial cable effectively reduces the tendency towards oscillation and regeneration. These cables should be connected as shown on drawing #P208.

Each BC-458 Kit now contains the following cable:

- 18" - RG58A/U for coax "F" (from oscillator stator to band switch)
- 9' - #21-204 for coax "A" and "B" (RF and B plus)

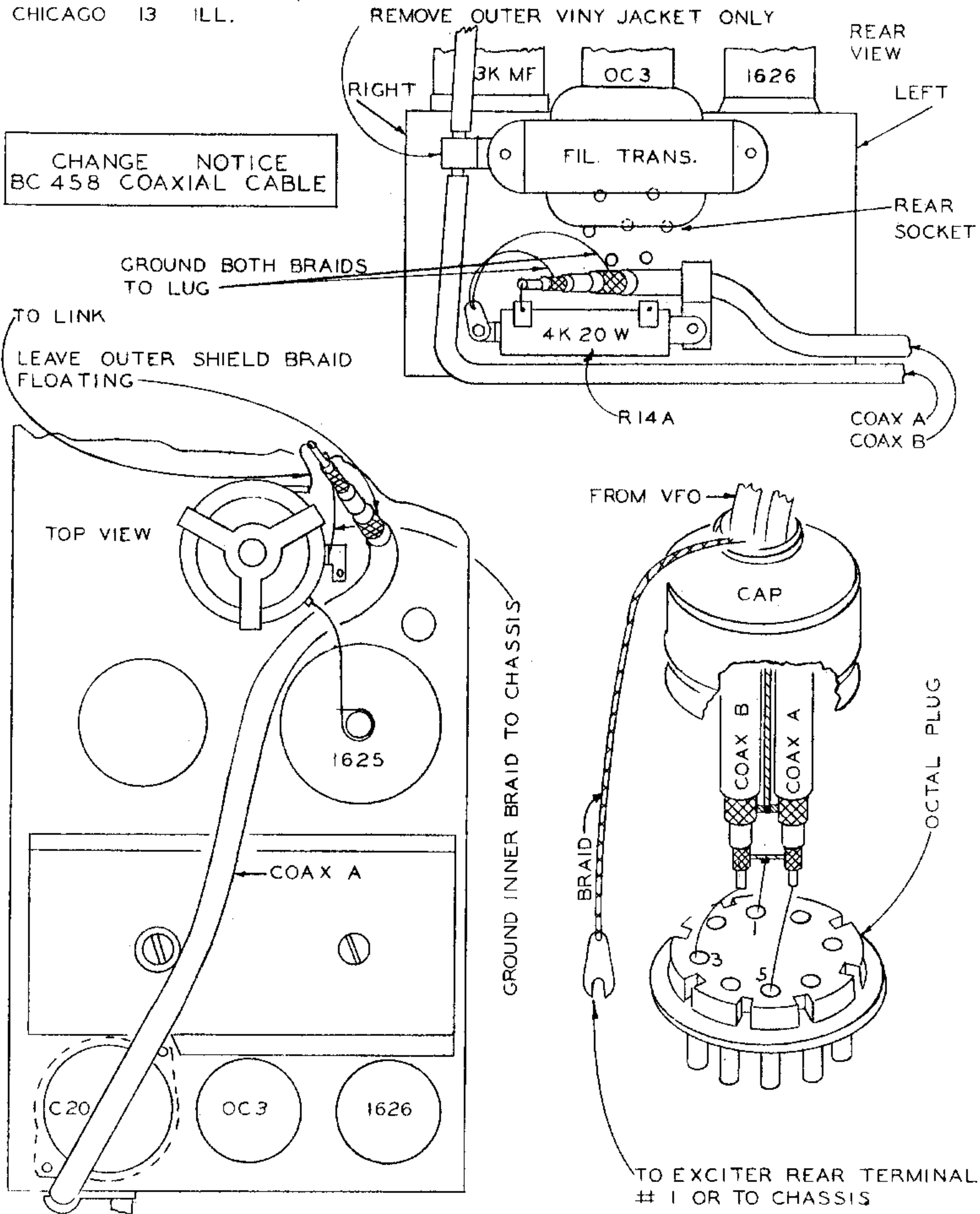

BC-458 CHANGE NOTICE

In order to provide sufficient output when the 1625 is operating as a frequency tripler to 16 mc. (for 40 meter operation) the Voltage Regulator tube has been changed to a VR105. The dropping resistor for the Regulator Tube is now 4000 ohms.

If the 1625 grid bias resistor (located on terminals 6 and 7 on the VR tube socket) is increased to 100,000 ohms, additional reserve output will be obtained.

458 CHANGE NOTICE

The black oxide screws sometimes make poor R.F. contact and must be replaced. Before installing coax F, remove two black oxide #3 nuts, screws and washers from the right side of chassis near rear, as shown. These two screws hold two mica capacitors and two ground lugs to the side of chassis. The two ground lugs should be cleaned, if necessary, to insure good contact. Two #4-40 x 5/8" screws, nuts and lockwashers are used to replace the #3 screws, as shown.

Place a lockwasher under head of screw; push through hole in side of chassis and capacitor. A #4 nut is used to hold lug and capacitor to inside of chassis. If your 458 is painted black wrinkle, it is advisable to scratch paint from around the two holes before adding #4 screws.

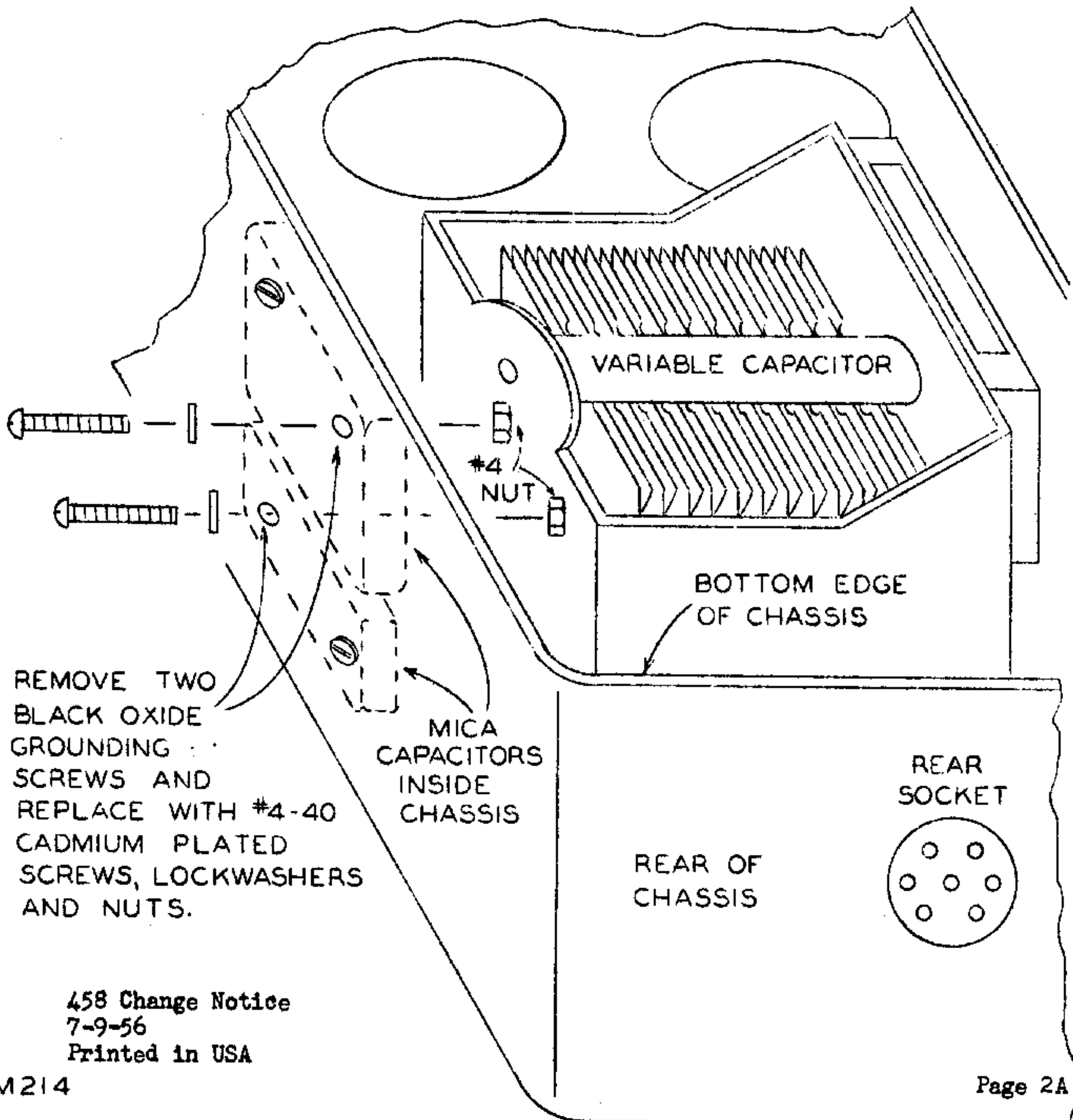

458 Change Notice
7-9-56
Printed in USA

DETAILED CONVERSION INSTRUCTIONS
FOR
BC-457, BC-458, BC-459 WITH 12 VOLT OPERATION

This modification procedure allows the installation of a VR105 into the socket originally intended for the crystal calibrator and mounts the filament transformer and dropping resistor on the rear of the chassis.

NOTE: Socket connections read clockwise from underneath chassis.
Pin #7 on power socket (rear) is the center pin.

1. CRYSTAL SOCKET (Center octal socket rear of chassis)
 - a. Remove resistor between pin #3 and #8 - discard.
 - b. Remove black lead from pin #3 and take out of circuit.
 - c. Unsolder end of resistor from pin #5.
 - d. Unsolder two black leads from pin #5.
 - e. Disconnect black wire from pin #5 on rear socket and remove from circuit.
 - f. Reconnect remaining black wire (from pin #5) and end of resistor (e above) to pin #6.
 - g. Add a jumper between pins #1 and #2.
 - h. At the 1626 socket - remove red lead from pin #4 and tape end, or remove from circuit.
 - i. Solder a jumper from 1626 socket pin #4 to VR tube socket pin #5.
2. REAR SOCKET (inside chassis)
 - a. Remove the white lead from pin #1 and discard.
 - b. Remove red lead from pin #4 and tape end.
 - c. Remove two black leads from pin #2 and discard.
 - d. Remove black lead from rear socket pin #6 and VR socket pin #7 and discard.
 - e. Remove Red-White lead from rear socket pin #7 and attach to VR socket pin #5.
 - f. Solder a jumper from VR socket pin #5 to rear socket pin #4.
 - g. On rear socket - solder a jumper from pin #3 to pin #4.
3. EYE TUBE SOCKET (VT138 - 1629)
 - a. Remove the two resistors from pin #8 and discard. Add a jumper from pin #2 to pin #7.
4. AT THE RELAY (underneath the chassis, centered on right side viewing from the front)
 - a. Cut black and tan leads from relay coil and remove from circuit.
 - b. Cut the two red leads from relay contacts and tape separately or remove from circuit.
 - c. Cut the bare wire at relay that goes to the 1625 socket pin #6.
 - d. Remove and discard the relay. Enlarge the hole which formerly held relay and mount a solder lug with #6 hardware.
 - e. Solder bare wire from 1625 socket pin #6 to grounded solder lug.

5. 1625

- a. Add a jumper from pin #1 to pin #7 on the 1625 socket next to the tuning shaft.

6. FILAMENT TRANSFORMER 12 volts - 1 amp

- a. Mount on 1/2" spacers slightly above (horizontally) rear socket with secondary (green) leads down. Place two solder lugs under screw heads inside chassis.
- b. Trim secondary leads to proper length and solder into rear socket pins #1 and #6 (from outside)
- c. Drill hole for 3/8" grommet slightly below and to left of rear socket (viewed from rear).
- d. Solder filament transformer primary leads to rear socket pins #2 and #5 outside of chassis.
- e. Solder a .005 ceramic by-pass condenser from pin #2 on rear socket to ground lug.
- f. Solder a .005 ceramic by-pass condenser from pin #5 on rear socket to ground lug.
- g. Insert proper length of primary A.C. cord through grommet hole, tie a knot and solder leads to pins #2 and #5 of rear socket.

VR TUBE DROPPING RESISTOR 4000 ohm 20 watts

- a. Mount a 4000 ohm 20 watt resistor on the back of the chassis slightly below and to the left of rear socket. (Resistor is mounted outside chassis for heat radiation.)
- b. From outside chassis, solder a jumper from rear socket pin #4 to low potential end of 4000 ohm 20 watt resistor.
- c. Plate voltage is supplied from the Exciter through an octal plug and cable, as shown on Page 2. Inner conductor is soldered to one lug of 4000 ohm 20 watt resistor.

ADAPTING THE BC-458 FOR 20 AND 80 METER OPERATION

The BC-458 (5.3 to 7 mc.) is recommended as a VFO rather than the BC-457 (4 to 5.3 mc.) for greater stability.

ADJUSTING THE FREQUENCY RANGE

After completing the proper modifications, plug the VFO into the socket on the rear of the Exciter. Remove the oscillator section shield can. Set the single plate adjustment trimmer to mid-capacity. Now loosen the two bristol set screws on the oscillator padding capacitor. It will be necessary to increase the capacity until the oscillator is at 5 mc. with the dial set at 5.3 mc. after the shield can is replaced. The iron core slug will change the frequency several hundred kilocycles and the capacity should be increased in small steps until 5 megacycles is reached. By drilling a $3/8$ " hole approximately $3/4$ " below the present one, the adjustment can be made with the shield can in place. If your receiver does not tune to 5 mc., use the Exciter tuned to 4 mc. with some carrier inserted. After the correct setting has been determined, be sure to tighten the set screws.

The amplifier air padder located beneath the chassis must be tuned to the new oscillator frequency. Adjust for maximum VR tube brilliance, or for maximum Exciter output with the VFO coupling set to about 4.

BANDSPREAD MULTIBAND OPERATION OF THE BC-458

By the addition of a bandswitch, three miniductors and a 50 uufd. variable capacitor, operation in the 160, 80, 40, 20 and 15 meter bands is possible. CW operation from 21,000 to 21,200 is not recommended with this conversion, but satisfactory performance is obtained in the rest of the 21 mc. band.

It is suggested that whenever the 1625 stage is used as a frequency multiplier, the filament of the oscillator tube be operated on direct current to minimize hum. One method of obtaining this DC is to use a 12 volt filament transformer for the unit, with a full wave bridge rectifier and a filter capacitor of at least 1000 mfd.

Bandspread is accomplished by carefully removing the rotor plates from both the oscillator and amplifier variable tuning capacitors. Those plates farthest from the worm gear drive should be removed so that only 8 rotors remain in use in each tuning capacitor. With the capacitors open, gently rock the plates, one at a time, with a long nose pliers until they become loose. If too much force is used, the rotor shaft may become dislodged and you will then very likely spend the rest of the day and evening recovering the small ball bearings and trying to figure out a method of reassembling everything. Care should also be taken not to exert any pressure on the stator sections as this can cause the glass insulating beads to fall out.

The 50 mmfd. variable capacitor should be mounted in the hole occupied by the antenna binding post. File two notches in the edges of the hole to accept the mounting screws.

For 40 meter operation a coil consisting of 3-1/4 turns of #3014 B & W Miniductor (8 turns per inch) is shunted across the amplifier plate inductor so that it will triple into the range of 16 to 16.3 mc.

For 160 meters a coil consisting of 6-1/2 turns of #3015 B & W Miniductor (16 turns per inch) is used to double to 10,800 to 11,000 kc. Five turns are used for 15 meters which requires 12,250 to 12,450 kc.

The antenna loading coil assembly should be removed and a metal plate installed in the window.

Suggested plate dimensions:

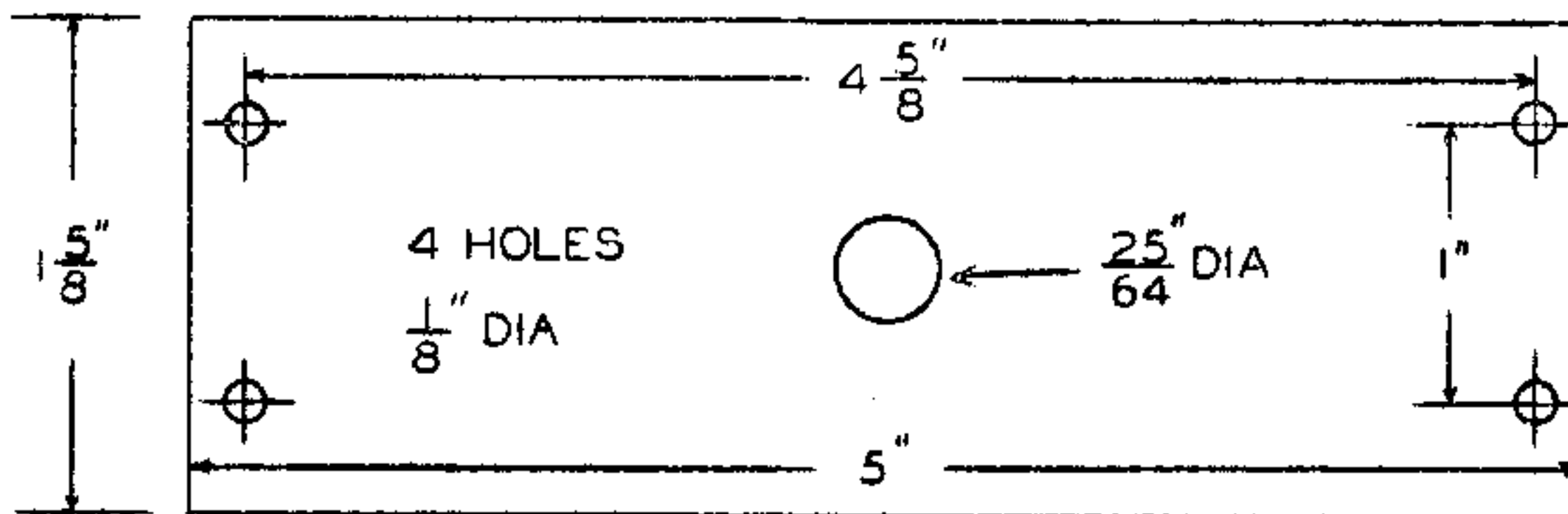

The entire unit should rest on a sponge rubber pad or soft rubber feet.

ALIGNMENT PROCEDURE

Set receiver and exciter to 21,450 kc. Advance the CARRIER knob. With the VFO switch in the 21 mc. position and the dial at 7.0 mc., adjust the oscillator air padder (inside the can) for zero beat. This will occur with a little more than half capacity and the slot in the shaft will be slightly beyond the horizontal position, at an angle about 8:30 to 2:30.

With the receiver and exciter tuned to 4.0 mc., set the VFO bandswitch to 80 meters and dial to 5.3 mc. Tune the 50 mmfd. APC capacitor for zero beat. Zero beat should occur with the plates of this capacitor about 95% meshed. If zero beat occurs at less than 95% capacity you have selected the wrong signal at 21,450 kc. Peak amplifier air padding capacitor (under the chassis) for maximum VR tube brilliance or maximum exciter output with the VFO loading set at 4.

Now return to the 21 mc. band. Slowly replace the large shield cover on the BC-458 and observe the effect upon the output of the exciter. Replacing this cover reduces the inductance of the coils and increases the

resonant frequency. When the cover is off, the coil should have slightly more inductance than necessary. The inductance may be adjusted by breaking the polystyrene strip so that the last half turn can be varied to trim the inductor to the required value. This effect must also be checked on 40 and 160 meters.

CALIBRATION CHART FOR BANDSPREAD VFO

| | | | |
|------|------|-------|------|
| 1800 | 6485 | 7000 | 6248 |
| 1825 | 6531 | 7100 | 6363 |
| | | 7200 | 6481 |
| 1875 | 6627 | 7300 | 6605 |
| 1900 | 6674 | | |
| 1925 | 6724 | 14000 | 5300 |
| | | 14100 | 5562 |
| 3500 | 6585 | 14200 | 5844 |
| 3700 | 6153 | 14300 | 6153 |
| 3800 | 5844 | | |
| 3900 | 5562 | 21250 | 6715 |
| 4000 | 5300 | 21350 | 6855 |
| | | 21450 | 7000 |

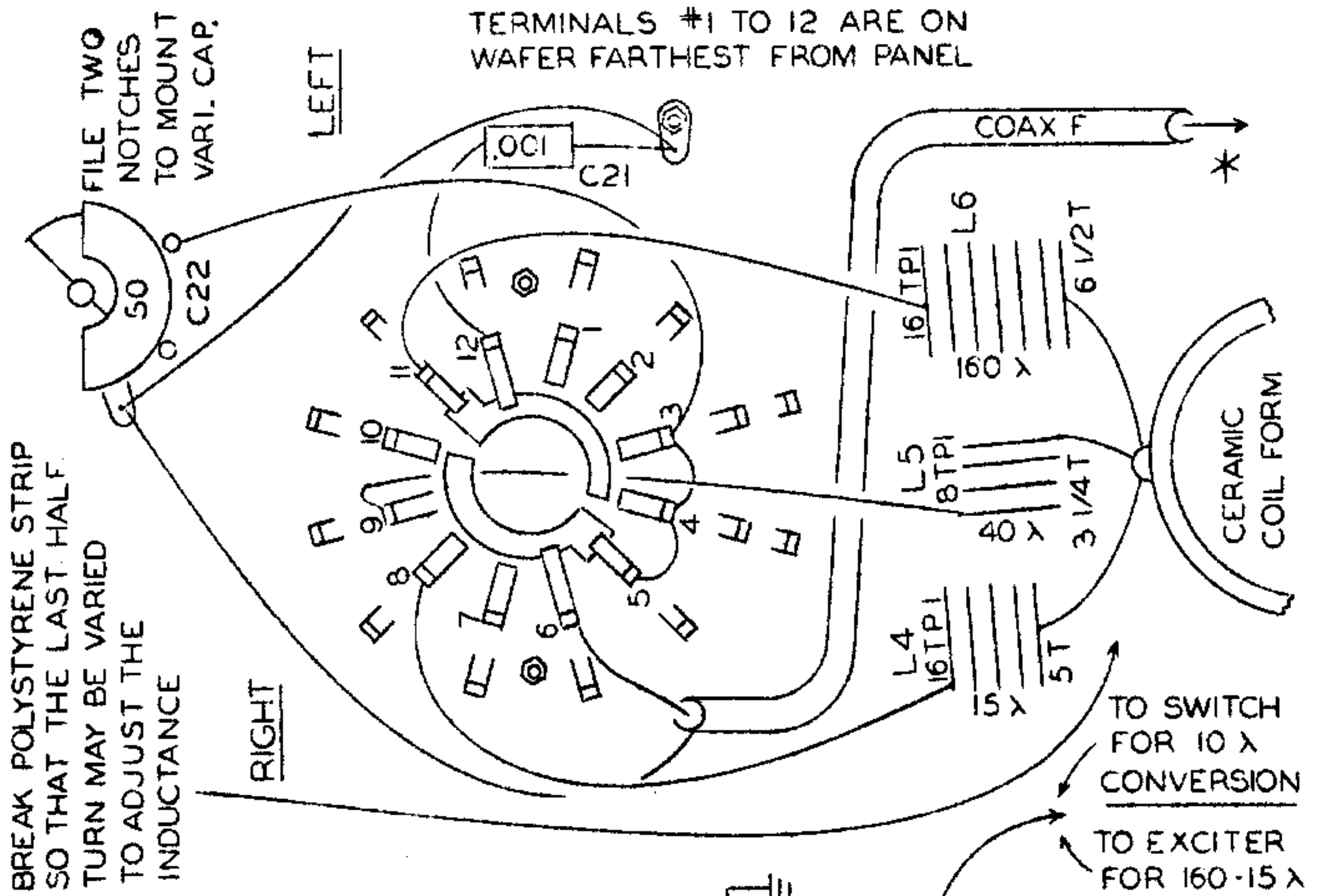

SWITCH SHOWN IN 160 λ POSITION

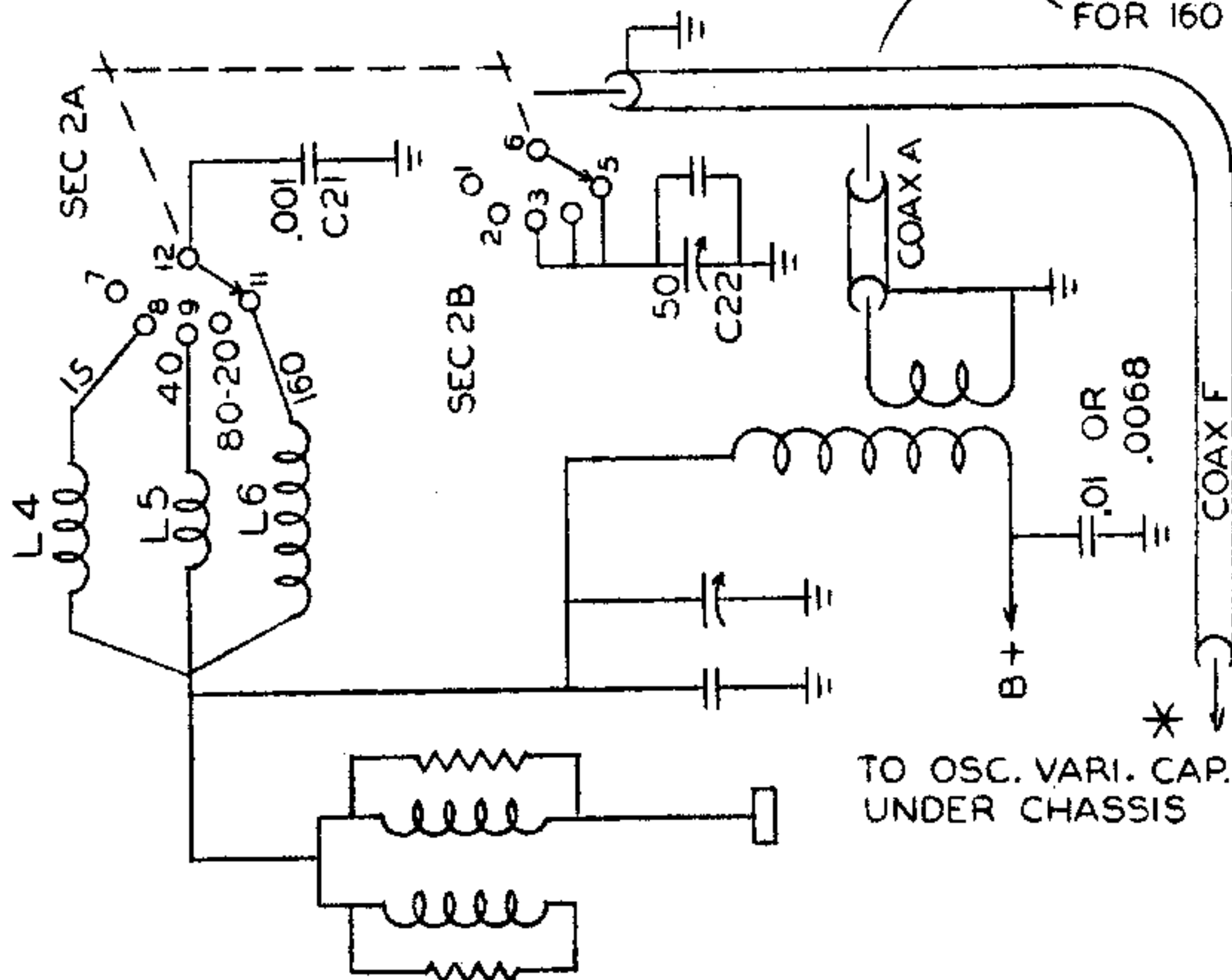

M217
 IOIMX
 VFO 10-20
 10-27-54 Rev. 12-4-58

FIG. 3

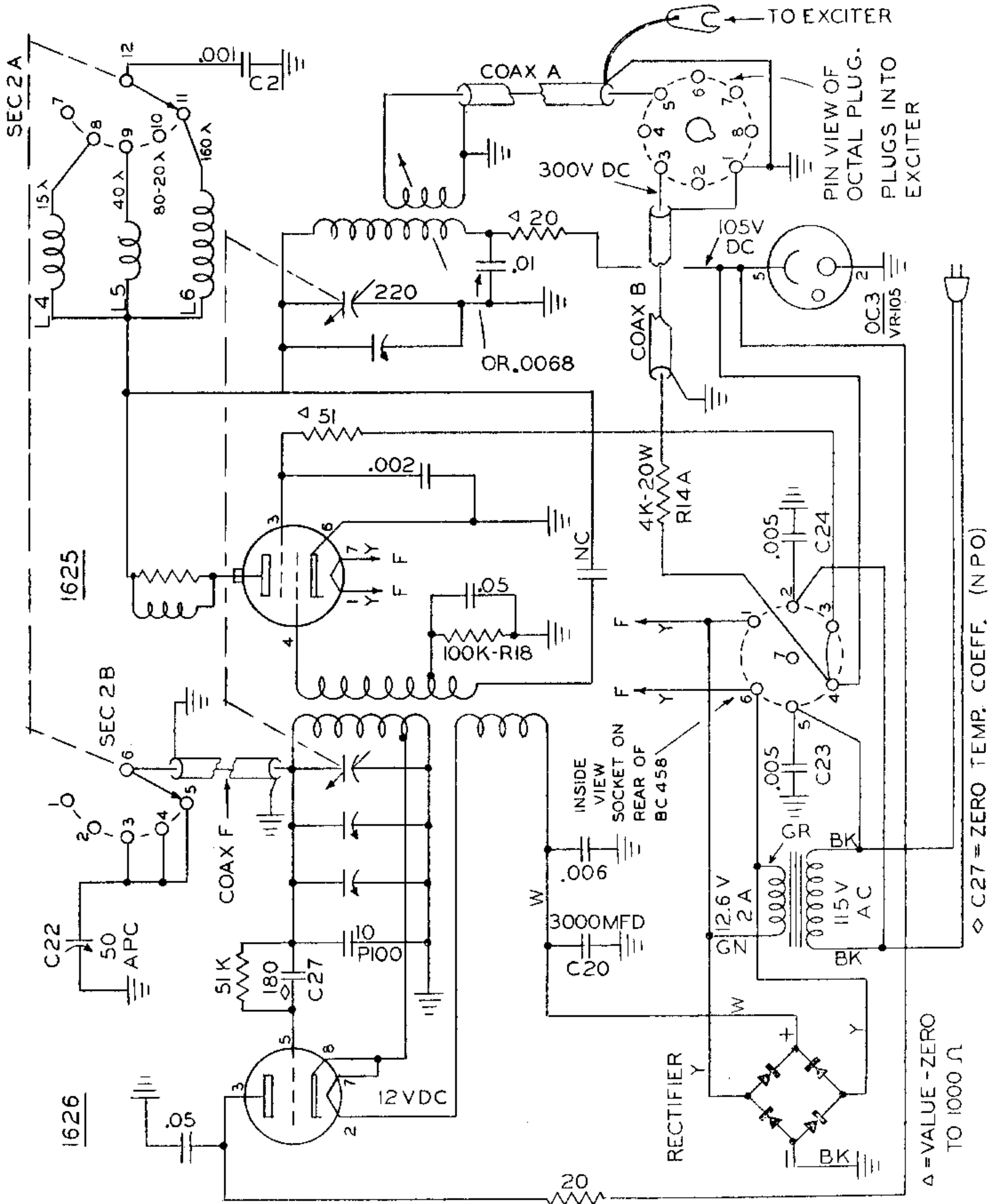

SCHEMATIC OF CONVERTED UNIT - BC458 VFO

FIG 4

MODEL 458K - 5 BAND BC-458 CONVERSION KIT WITH BANDSPREAD DIAL
 FOR OPERATION ON 160, 80, 40, 20 and 15 METERS
 PRICE COMPLETE - \$17.50

| | |
|--|--------|
| *1 - Calibrated dial scale | \$2.00 |
| *1 - 6X3/VR105 voltage regulator tube | 1.32 |
| *1 - 12 volt 2A filament transformer 27PF356 | 2.00 |
| *1 - Full wave bridge selenium rectifier 600 ma | 2.25 |
| *1 - Rectifier mounting bracket | .25 |
| *1 - 3000 mfd. 12V filter capacitor and mounting plate | 2.00 |
| *1 - Bandswitch, 4 pole 5 pos. and SPST, ceramic | 2.50 |
| *1 - Bandswitch mounting plate | .50 |
| *3 - Miniductors cut to size | 1.00 |
| *1 - 20 watt 4000 ohm resistor with mounting brackets | .66 |
| *1 - Octal male plug and cap. | .23 |
| *1 - 50 mmfd. var. capacitor, AFC | 1.23 |
| *1 - Capacitor, ceramic 10 mmfd. pos. 100 (White, Black, Black Brown) | .29 |

- 1 - Bristo Wrench
- 4 - Rubber Feet
- 4 - #6 sheet metal screws for rubber feet
- 2 - .005 mfd. ceramic capacitors
- 1 - .001 mfd. mica capacitor (10% tan)
- 1 - .006 or .0068 mica capacitor, tan. (For Navy T21/ARC5 only)
- 10 - Ft. RG58AU coaxial cable for RF and B plus
- 1 - Knob for bandswitch
- 2 - Transformer mounting spacers 7/16" long
- 1 - Line cord
- 2 - 3/8" grommets
- 3 - Cable clamps
- 6 - 4-40 screws, 4 nuts, 2 lockwashers
- 1 - #4 soldering lug
- 9 - #6 shakeproof ground lugs
- 2 - 3/8-32 nuts
- 1 - 3/8" lockwasher
- 3 - 6/32-1" screws
- 5 - 6/32-5/16" screws
- 8 - 6/32 nuts
- 9 - #6 lockwashers
- 12" white wire
- 56" yellow wire
- 12" bare hookup wire
- 6" spaghetti
- 48" lacing cord

Those items marked with an asterisk (*) are available individually.

458CP: An attractive gray wrinkle cabinet for the BC-458, 5 1/2" wide, 8-3/4" high and 13" deep with silk screened front panel and all holes drilled; matches Models 10 and 20 Multiphase Exciters. Identical in size with the Sideband Slicer. Price \$10.00

Model 458A-10: A crystal controlled converter to extend the BC-458 for operation from 28.4 to 29.4 mc. Fits inside the BC-458 case. (458K Kit required in addition) Wired and tested.....\$37.50 Kit.....\$27.50